

BRICK LINTEL  
Stretcher course brickwork

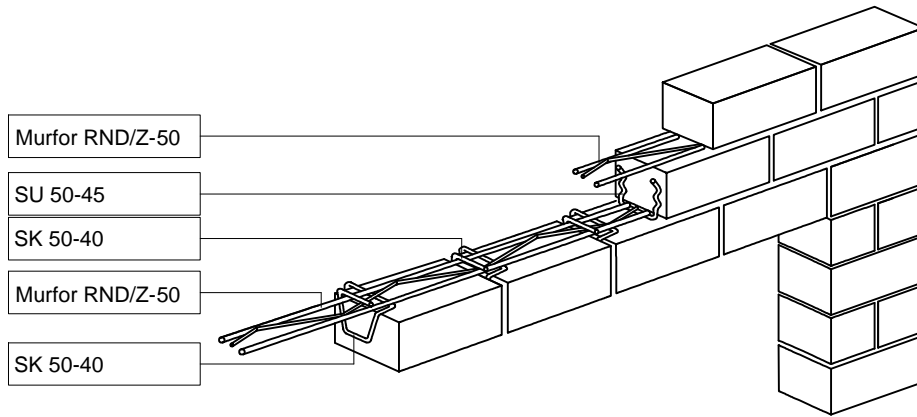

**S1-01**

Page 1 of 3



- Murfor RND/Z-50
- SU 50-45
- SK 50-40
- Murfor RND/Z-50
- SK 50-40

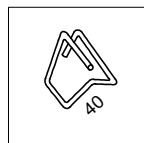

**HOOK BAUT SK 50-40**

Height (mm).....40  
Wire diameter (mm).....3  
Coating.....zinc\*

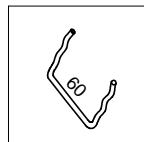

**HOOK BAUT SU 50-45**

Height (mm).....45  
Width (mm).....60  
Wire diameter (mm).....3  
Coating.....zinc\*

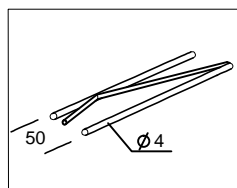

**REINFORCEMENT MURFOR RND/Z-50**

Width (mm).....50  
Length (m).....3,05  
Coating.....zinc\*

\*zinc coating reference 20 (according to EN 845-1+A1)

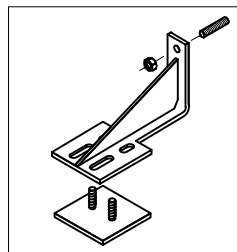

**BRACKET GSP**

Stainless steel 1.4301 (according to EN 10088-1)

Lintel consist of at least three course of bricks bonded with mortar. Lintel hooks SK 50-40 should be placed into the mortar,in every vertical joint of the first row of brickwork. Reinforcement Murfor RND/Z is placed between first and second and between second and third rows. Rods extend beyond the opening edges by at least 250 mm in both sides.

**MOUNTING OF BRICK LINTEL S1-02**

In this way we mount lintels up to 2m. In case of large openings suspended brackets should be used (S1-03).

Quantity of brackets and their arrangement above openings are calculated separately in every individual case. The irrigation is very important for silicate bricks masonry.

Class of mortar should be at least M100

# MOUNTING OF LINTEL Stretcher course brickwork



## S1-02

Page 2 of 3

1

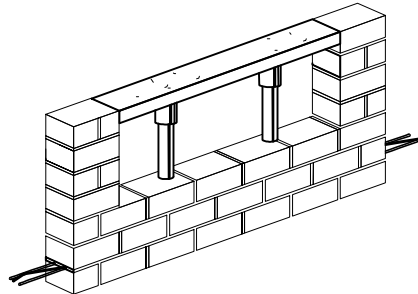

Construction of formwork

4

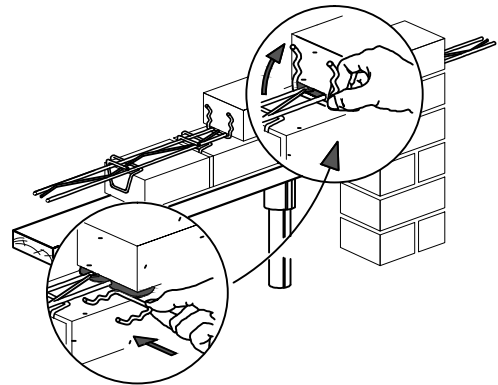

Lintel hooks SU 50-45 in every second vertical joint of the second course

2

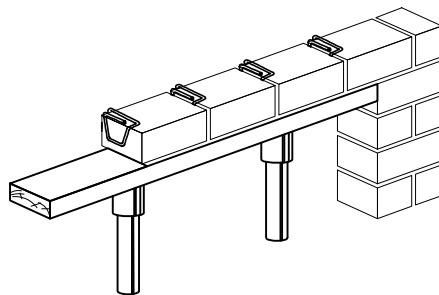

Lintel hooks SK 50-40 in every vertical joint of the first course

5

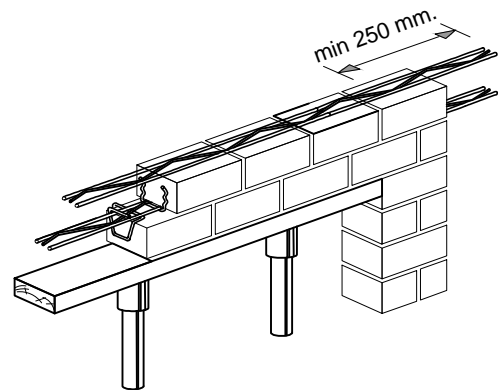

Reinforcement Murfor RND/Z-50 in the second course of brickwork. Further throughout the height, 1 reinforcement rod at every 300...500 mm

3

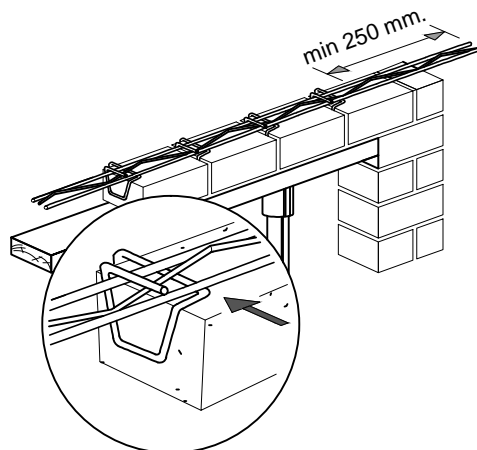

Reinforcement Murfor RND/Z-50 is inserted through grooves of lintel hooks. Reinforcement rods extend beyond the opening edges by at least 250 mm in both sides

6

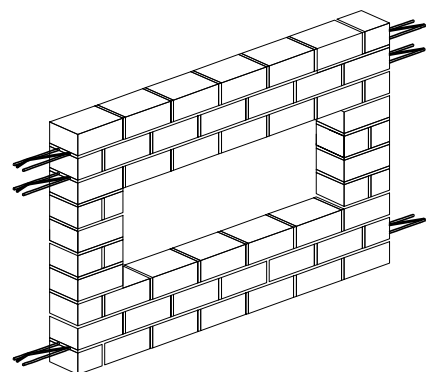

Formwork should be dismantled after 2 weeks

# MOUNTING OF LINTELS WITH SUSPENDED BRACKETS

Stretcher course brickwork

## S1-03

Page 3 of 3



1

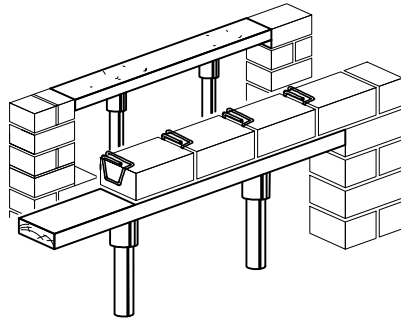

Construction of formwork. Lintel hooks SK 50-40 in every vertical joint of the first course

4

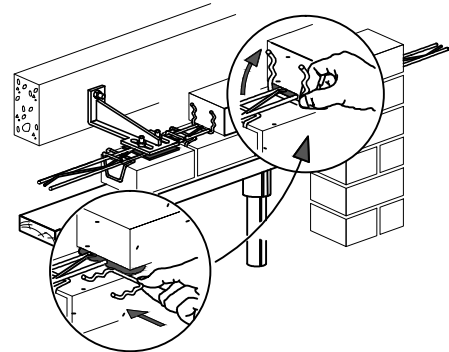

Lintel hooks SU 50-45 in every second vertical joint of the second course

2

Connection of reinforcement Murfor RND/Z-50 with the bottom part of suspended bracket GSP

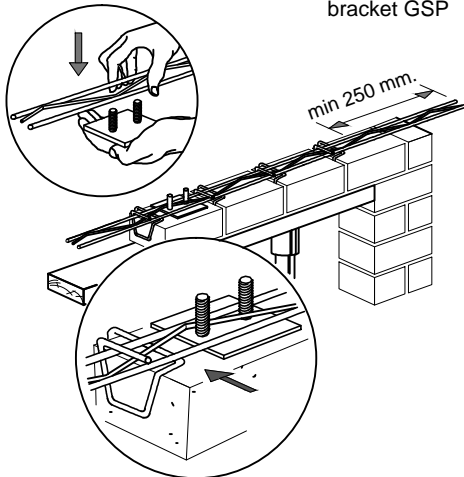

Reinforcement together with the plate should be inserted through grooves of lintel hooks

5

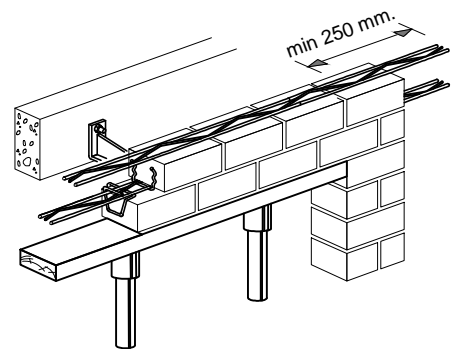

Reinforcement Murfor RND/Z-50 in the second and the third rows of brickwork. Further throughout the height, 1 reinforcement rod in every 300...500 mm

3

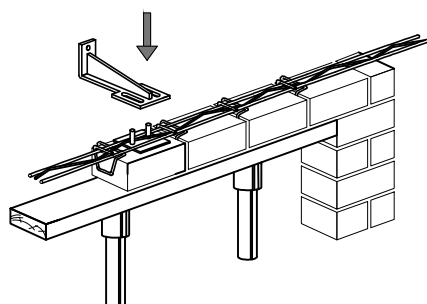

Fixation of suspended bracket GSP

6

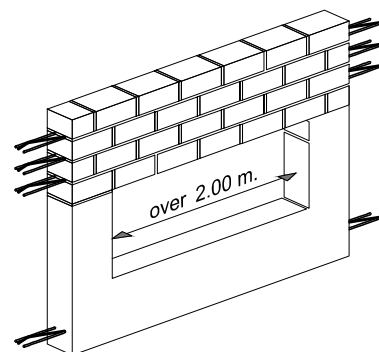

Formwork should be dismantled after 2 weeks